



# RUBIK Pi 3 V02 数据手册

版本编号：V1.2

发布日期：2025-03-26



## 修订记录

版本编号	发布日期	修订内容
1.0	2024 年 12 月 9 日	首次发布。
1.1	2025 年 3 月 14 日	<ul style="list-style-type: none"><li>• 增加图 3-1 和附录 1。</li><li>• 更新表 3-1。</li><li>• 支持的操作系统中添加了 Debian 12。</li><li>• 将所有 RUBIK Pi 3 V01 配图替换为 RUBIK Pi 3 V02 版。</li><li>• 工作温度更新为 -20°C – 70°C。</li><li>• 更新 40-pin 连接器接口定义。</li></ul>
1.2	2025 年 3 月 26 日	添加表 3-3 脚注。



# 目录

1. 产品概述.....	1
2. 特性简介.....	3
2.1. 系统框图.....	3
2.2. 功能分布.....	4
2.3. 电气特性.....	4
2.3.1. 输入电源要求.....	4
2.3.2. 电源输出要求.....	5
2.4. 结构尺寸.....	6
3. 接口特性.....	7
3.1. 40-pin 连接器接口.....	7
3.2. HDMI 接口.....	8
3.3. Ethernet 接口.....	8
3.4. USB 接口.....	9
3.4.1. USB 3.1 Gen1 Type-C.....	9
3.4.2. USB 3.0 Type-A.....	9
3.4.3. USB 2.0 Type-A.....	9
3.5. 3.5mm 音频接口.....	10
3.6. 摄像头接口.....	10
3.7. M.2 接口.....	12
3.8. Wi-Fi.....	13
3.9. 蓝牙.....	13
3.10. 风扇接口.....	14
3.11. RTC 电池接口.....	14
3.12. Micro USB 转 UART 调试接口.....	15
3.13. 按键.....	15
3.13.1. PWR 键.....	15
3.13.2. EDL 键.....	15
3.14. LED.....	16
3.14.1. 电源指示 LED.....	16
3.14.2. RGB LED.....	16
4. 注意事项.....	17
4.1. 工作环境.....	17



4.2. 静电防护 ..... 17

4.3. 警告 ..... 17

4.4. 安全使用说明 ..... 17

附录 1. Compliance and Certificate Information..... 18

# 1. 产品概述

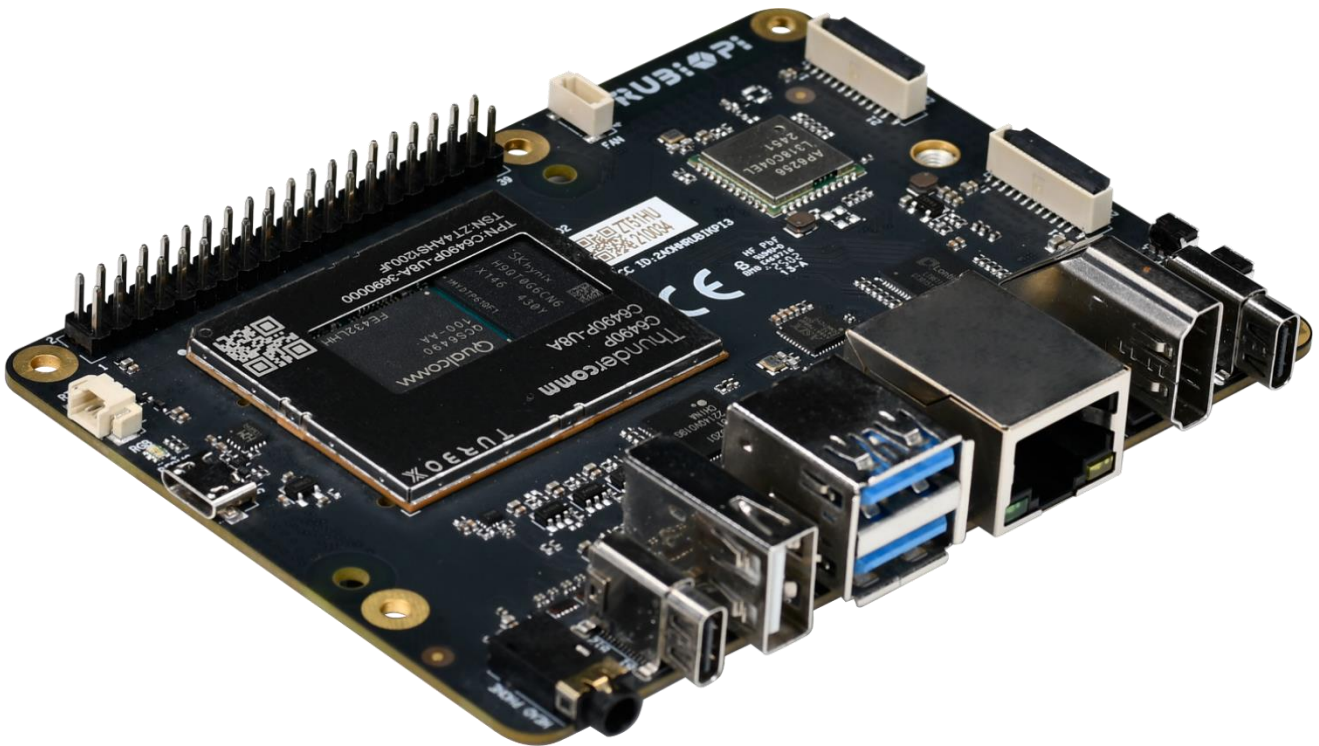

类别	RUBIK Pi 3 特性
平台信息	Qualcomm® QCS6490 RAM 8 GB LPDDR4x ROM 128 GB UFS2.2
视频接口	1 路 HDMI 1.4 输出 (最高 4K 30 Hz) 1 路 DP over USB Type-C (最高 4K 60 Hz) 2 路摄像头接口 (4-lane MIPI CSI D-PHY)
音频接口	1 路 3.5mm 耳机接口
功能接口	1 路 USB Type-C (USB 3.1 Gen 1) 2 路 USB Type-A (USB 3.0) 1 路 USB Type-A (USB 2.0) 1 路 1000M 以太网 (RJ45) 1 路 UART 调试 (通过 Micro USB) 1 路 M.2 Key M 接口 (PCIe3.0 2-lane) 40-pin 连接器支持多种接口选项:



类别	RUBIK Pi 3 特性
	<ul style="list-style-type: none"><li>• 多达 28 个 GPIO</li><li>• 多达 2 路 I2C</li><li>• 多达 3 路 UART</li><li>• 多达 3 路 SPI</li><li>• 1 路 I2S (PCM)</li><li>• 1 路 PWM</li></ul>
其他	1 个 PWR 按键 1 个 EDL 按键 1 个 RGB LED 2-pin RTC 电池接口 4-pin PWM 风扇接口
无线连接	无线网 (IEEE 802.11 a/b/g/n/ac Wi-Fi) 蓝牙 (BT 5.2) 板载 PCB 天线
供电	Power Delivery over Type-C, 12V 3A
工作环境	工作温度: -20°C – 70°C
尺寸	100mm x 75mm x 25mm
操作系统	Android 13 Qualcomm Linux Debian 12 *Canonical Ubuntu for Qualcomm platforms

\*计划中。

## 2. 特性简介

### 2.1. 系统框图



图 2-1. RUBIK Pi 3 系统框图

## 2.2. 功能分布

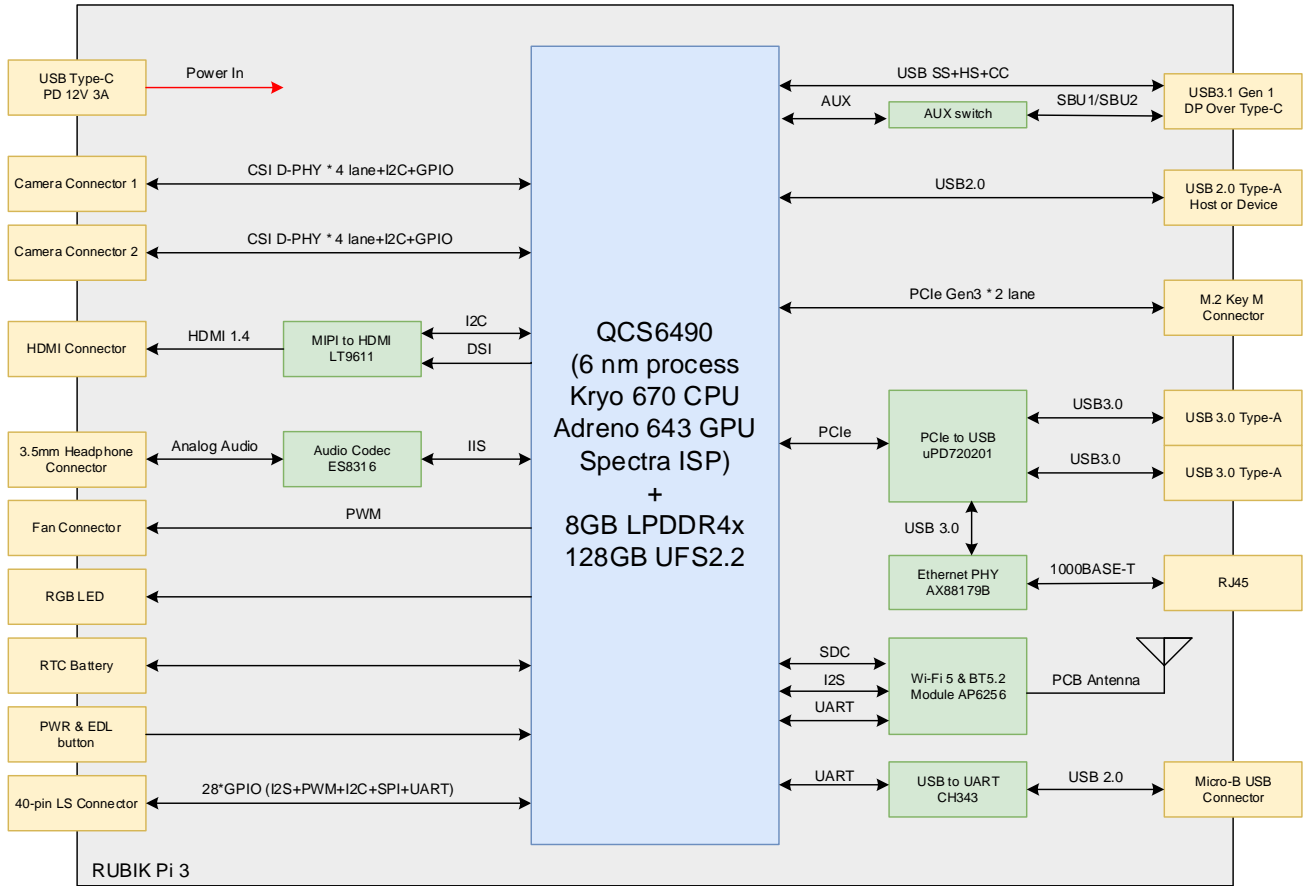

图2-2. 主要部件位置

表 2-1. 接口列表

编号	接口	编号	接口
1	RTC 电池接口	10	Power Delivery over Type-C
2	Micro USB (UART 调试)	11	PWR 按键
3	TurboX C6490P SOM	12	EDL 按键
4	3.5mm 耳机接口	13	摄像头接口 2
5	USB Type-C with DP (USB 3.1)	14	摄像头接口 1
6	USB Type-A (USB 2.0)	15	Wi-Fi/BT 模块
7	2 x USB Type-A (USB 3.0)	16	风扇接口
8	1000M 以太网	17	40-pin 连接器
9	HDMI OUT	18	M.2 Key M 接口

## 2.3. 电气特性

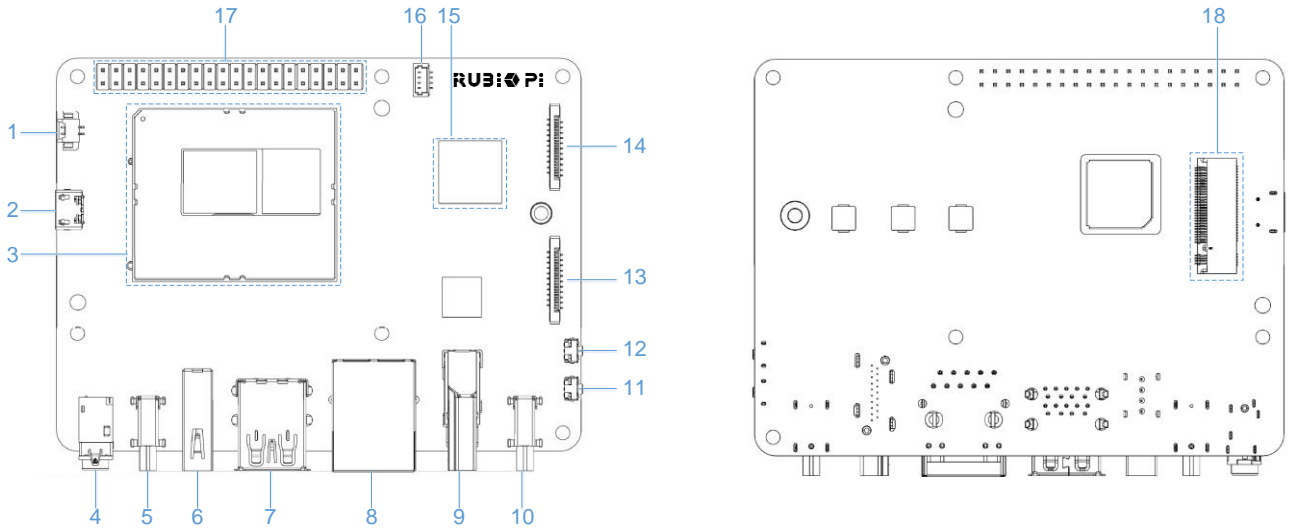
### 2.3.1. 输入电源要求

RUBIK Pi 3 集成了 PD 协议的协商 IC，最高支持 PD3.0。推荐使用支持 12V 3A PD3.0 协议 Type-C 接口的电源适配器。



当电源适配器符合规格并成功协商后，电源指示灯将亮起（黄绿色，如下图所示）。不满足以上条件的电源适配器设备，电源指示灯将不会点亮并无法开机。



图2-3. 电源指示灯

### 2.3.2. 电源输出要求

RUBIK Pi 3 在接入支持 12V 3A PD 协议的电源适配器后，每个接口对外输出的最大电流如下表。

表 2-2. 各接口对外输出最大电流

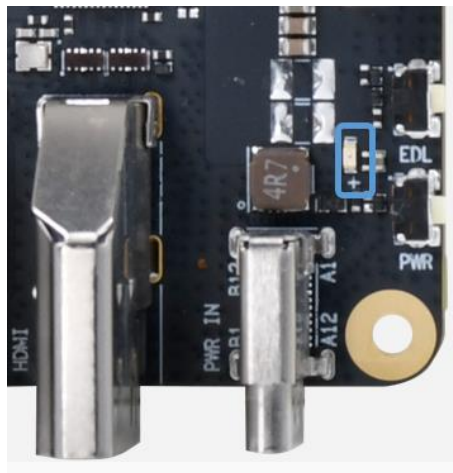
接口类型	输出电压	最大输出电流	备注
USB 3.0 Type-A - 1	5V	1.5A	3 个 USB 口同时输出的总电流不要超过 3A。
USB 3.0 Type-A - 2	5V	1.5A	
USB 2.0 Type-A	5V	1.5A	
40 Pin GPIO	5V	1A	
	3.3V	1A	
HDMI	5V	100mA	
M.2 Key M	3.3V	1A	
Camera 1	3.3V	300mA	
Camera 2	3.3V	300mA	

当超过最大输出电流时，会触发输出电源保护或系统重启。

建议不要使用 RUBIK Pi 3 的 USB 口给消耗电流较大的 USB 外设，如 USB 风扇、音箱或显示屏等供电。



## 2.4. 结构尺寸



图2-4. RUBIK Pi 3 尺寸

\*以上标注单位均为 mm。

## 3. 接口特性

### 3.1. 40-pin 连接器接口

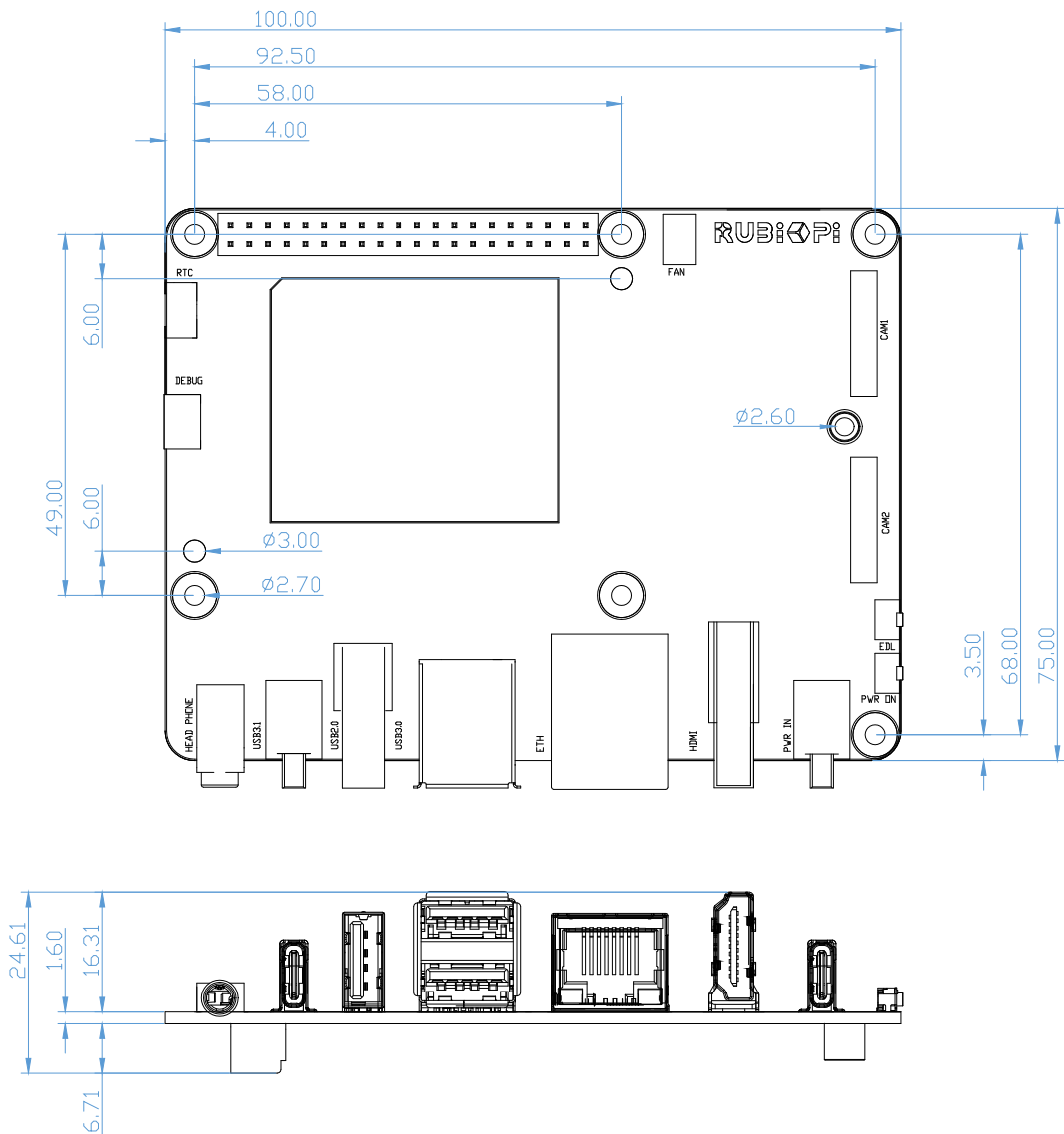

图3-1. 40-pin 连接器引脚默认功能

表3-1. 40-pin 连接器引脚定义

Fuction5	Fuction4	Fuction3	Fuction2	Fuction1	Pin#	Pin#	Fuction1	Fuction2	Fuction3	Fuction4	Fuction5	Fuction6
VCC3V3					1	2	VCC5V					
			<b>I2C1_SDA</b>	GPIO_4	3	4	VCC5V					
			<b>I2C1_SCL</b>	GPIO_5	5	6	GND					
<b>I2S1_MCLK</b>				GPIO_105	7	8	GPIO_10		SPI2_SCLK	<b>UART2_TXD</b>		
		GND			9	10	GPIO_11		SPI2_CS	<b>UART2_RXD</b>		
	UART2_CTS	SPI2_MISO	I2C2_SDA	<b>GPIO_8</b>	11	12	GPIO_101				<b>I2S1_CLK</b>	
	UART6_CTS	SPI6_MISO	I2C6_SDA	<b>GPIO_24</b>	13	14	GND					
	UART6_RTS	SPI6_MOSI	I2C6_SCL	<b>GPIO_25</b>	15	16	<b>GPIO_26</b>		SPI6_SCLK	UART6_TXD		
VCC3V3					17	18	<b>GPIO_27</b>		SPI6_CS	UART6_RXD		
	UART12_RTS	<b>SPI12_MOSI</b>	I2C12_SCL	GPIO_49	19	20	GND					
	UART12_CTS	<b>SPI12_MISO</b>	I2C12_SDA	GPIO_48	21	22	<b>GPIO_44</b>					
	UART12_TXD	<b>SPI12_SCLK</b>		GPIO_50	23	24	GPIO_51		<b>SPI12_CS</b>	UART12_RXD		
GND					25	26	<b>GPIO_55</b>					
			I2C3_SDA	<b>GPIO_12</b>	27	28	<b>GPIO_13</b>	I2C3_SCL				
	UART8_CTS	SPI8_MISO	I2C8_SDA	<b>GPIO_32</b>	29	30	GND					
	UART8_RTS	SPI8_MOSI	I2C8_SCL	<b>GPIO_33</b>	31	32	<b>PM_C_GPIO_09</b>					PWM
	UART8_TXD	SPI8_SCLK		<b>GPIO_34</b>	33	34	GND					
<b>I2S1_WS</b>				GPIO_103	35	36	<b>GPIO_9</b>	I2C2_SCL	SPI2_MOSI	UART2_RTS		
	UART8_RXD	SPI8_CS		<b>GPIO_35</b>	37	38	GPIO_102				<b>I2S1_DIN</b>	
GND					39	40	GPIO_104				<b>I2S1_DOUT</b>	

说明：蓝色加粗标注的是默认功能。

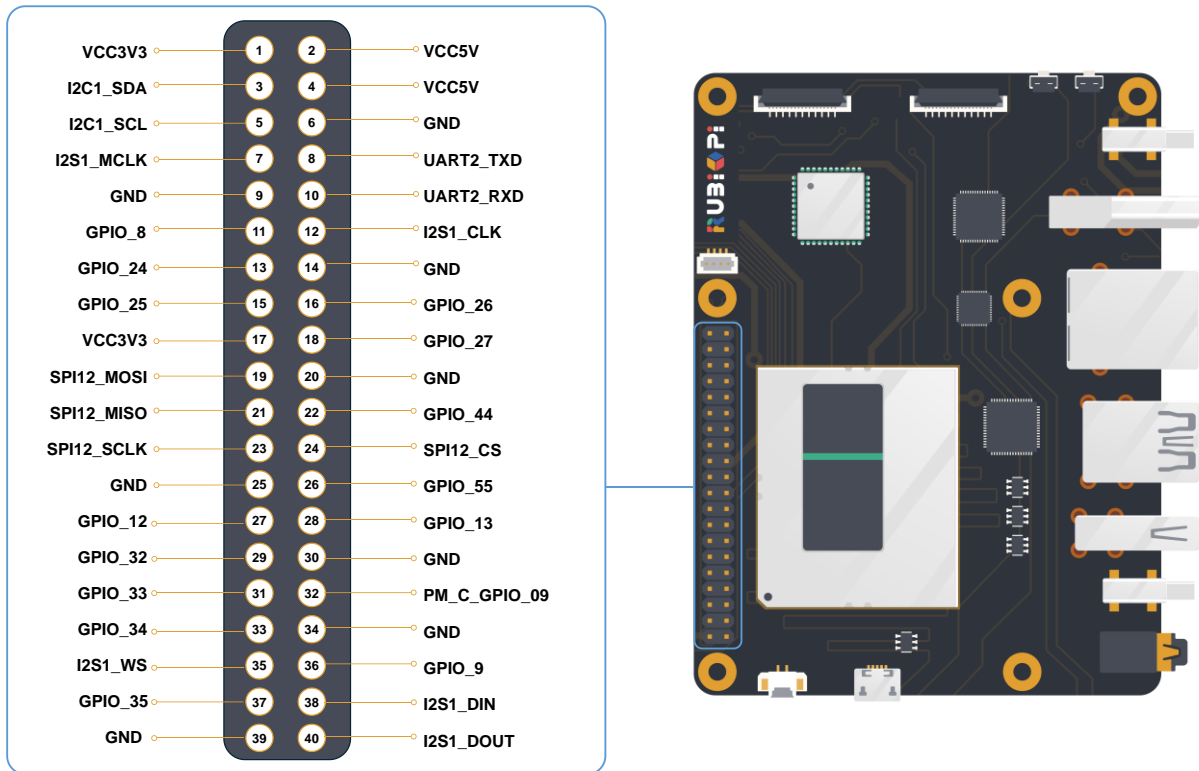
RUBIK Pi 3 共引出 28 个 GPIO，默认配置为 2 路 I2C、1 路 UART、1 路 SPI、1 路 I2S、1 路 PWM IO 及 9 个 GPIO。

所有 GPIO 电平均为 3.3V，其中 I2C 的 GPIO（4、5、12、13）为带上拉电阻的开漏输出模式，上拉电阻为 4.7 k $\Omega$ ；其他 GPIO 为推挽输出模式，受板内电平转换 IC 限制，外部连接信号的外部上拉或下拉电阻不能小于 50 k $\Omega$ 。

相同 QUP 的 GPIO 可灵活配置为 UART 或 SPI，具体请参照用户手册。

连接器为 2.54mm 间距，兼容绝大部分开源生态开发板的扩展板。

## 3.2. HDMI 接口

RUBIK Pi 3 配有标准尺寸 HDMI 接口，兼容 HDMI1.4 协议，HDMI 接口输出分辨率最高可达 4K 30Hz，支持 CEC 功能及 5V DDC 和 HPD 接口。

## 3.3. Ethernet 接口

RUBIK Pi 3 提供标准 RJ45 接口，带 Link 及 Active 指示灯，最高支持 1000 Mbps 全双工。



图3-2. Link & Active 指示灯

## 3.4. USB 接口



图3-3. USB 接口

### 3.4.1. USB 3.1 Gen1 Type-C

RUBIK Pi 3 带有 1 个标准 USB 3.1 Gen1 Type-C 接口，最高支持 5 Gbps 读写速率，支持 Type-C with DisplayPort v1.4，可通过 Type-C to DP 转接线输出最高分辨率为 4K 60Hz。

默认该口作为 ADB 调试接口。

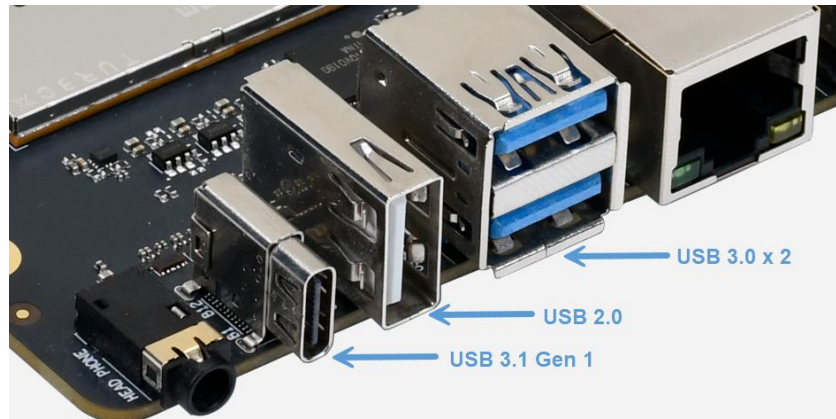
### 3.4.2. USB 3.0 Type-A

两个标准 USB 3.0 Type-A 接口，单路 USB 3.0 最大 4 Gbps 读写速率。

USB 3.0 Type-A 接口只能作为 Host。单口最大对外输出能力为 5V 1.5A，可单独控制电源输出。

### 3.4.3. USB 2.0 Type-A

一个标准 USB 2.0 Type-A 接口最高支持 480 Mbps 读写速率。该接口默认作为 Host，可通过软件配置此口为 Device 模式作为 ADB 接口。单口最大对外输出能力为 5V 1.5A（3 个 USB Type-A 共 3A），可单独控制电源输出。

### 3.5. 3.5mm 音频接口

3.5mm 音频接口按照 CTIA 耳机接口标准（国际标准）设计，支持左右声道和 Mic 输入。

耳机接口信号如下图所示，从右至左分别为：1-左声道、2-右声道、3-地线、4-麦克风。



图3-4. 耳机插口

表 3-2. 3.5mm 音频接口引脚定义

引脚编号	引脚名称
1	左声道
2	右声道
3	地线
4	麦克风

### 3.6. 摄像头接口



图3-5. 摄像头接口

RUBIK Pi 3 共有 2 个 22-pin 的摄像头接口。每个接口均支持 4-lane MIPI CSI D-PHY，并带有 1 路 I2C 及 2 个控制 GPIO。GPIO 电平为 3.3V，其中 I2C 信号为带有上拉电阻的开漏输出模式。连接器为 0.5mm 间距，pin 定义与 Raspberry Pi 5 使用的官方摄像头兼容。



软件已调通的摄像头列表：

- Raspberry Pi HQ Camera (IMX 477)
- Raspberry Pi Camera Module 2 (IMX 219)
- Raspberry Pi Camera Module 3 (IMX 708)

表 3-3. 摄像头接口引脚定义

摄像头接口 1		摄像头接口 2	
引脚名称	引脚编号*	引脚编号*	引脚名称
GND	22	22	GND
CSI0_LN0_M	21	21	CSI1_LN0_M
CSI0_LN0_P	20	20	CSI1_LN0_P
GND	19	19	GND
CSI0_LN1_M	18	18	CSI1_LN1_M
CSI0_LN1_P	17	17	CSI1_LN1_P
GND	16	16	GND
CSI0_CLK_M	15	15	CSI1_CLK_M
CSI0_CLK_P	14	14	CSI1_CLK_P
GND	13	13	GND
CSI0_LN2_M	12	12	CSI1_LN2_M
CSI0_LN2_P	11	11	CSI1_LN2_P
GND	10	10	GND
CSI0_LN3_M	9	9	CSI1_LN3_M
CSI0_LN3_P	8	8	CSI1_LN3_P
GND	7	7	GND
CAMERA1_PWR_EN(GPIO_57)	6	6	CAMERA2_PWR_EN(GPIO_58)
CAMERA1_GPIO(GPIO_18)	5	5	CAMERA2_GPIO(GPIO_19)
GND	4	4	GND
CAMERA1_I2C_SCL(GPIO_74)	3	3	CAMERA2_I2C_SCL(GPIO_70)
CAMERA1_I2C_SDA(GPIO_73)	2	2	CAMERA2_I2C_SDA(GPIO_69)
VCC3V3_OUT	1	1	VCC3V3_OUT

\*：本手册对应更换后的新版 CAM 连接器。新版 CAM 连接器仅为方便用户操作，并无性能差异。若使用早鸟版（丝印为 V01）硬件，请参考《RUBIK Pi 3 V01 数据手册》。

### 3.7. M.2 接口



图3-6. M.2 接口

RUBIK Pi 3 提供一个标准 M.2 插槽，用于连接 NVMe 存储，可安装 2280 规格（22\*80mm）M.2 SSD 硬盘。M.2 插槽最大支持 PCIe3.0 x 2。M.2 接口最大对外输出能力为 3.3V 2A，可单独控制开关。

表 3-4. M.2 接口引脚定义

引脚名称	引脚编号	引脚编号	引脚名称
GND	1	2	VCC3V3_OUT
GND	3	4	VCC3V3_OUT
NC	5	6	NC
NC	7	8	NC
GND	9	10	NC
NC	11	12	VCC3V3_OUT
NC	13	14	VCC3V3_OUT
GND	15	16	VCC3V3_OUT
NC	17	18	VCC3V3_OUT
NC	19	20	NC
GND	21	22	NC
NC	23	24	NC
NC	25	26	NC
GND	27	28	NC
PCIE1_RX1_M	29	30	NC

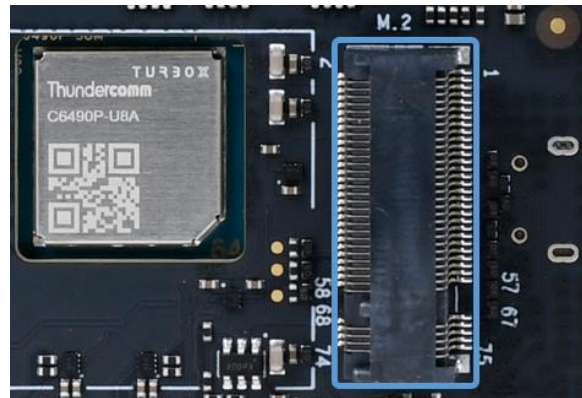



引脚名称	引脚编号	引脚编号	引脚名称
PCIE1_RX1_P	31	32	NC
GND	33	34	NC
PCIE1_TX1_M	35	36	NC
PCIE1_TX1_P	37	38	NC
GND	39	40	NC
PCIE1_RX0_M	41	42	NC
PCIE1_RX0_P	43	44	NC
GND	45	46	NC
PCIE1_TX0_M	47	48	NC
PCIE1_TX0_P	49	50	PCIE_RESET_N <sup>(1)</sup>
GND	51	52	PCIE_CLK_REQ_N <sup>(1)</sup>
PCIE1_REFCLK_M	53	54	PCIE_WAKE_N <sup>(1)</sup>
PCIE1_REFCLK_P	55	56	NC
GND	57	58	NC
...	...	...	...
NC	67	68	NC
NC	69	70	VCC3V3_OUT
GND	71	72	VCC3V3_OUT
GND	73	74	VCC3V3_OUT
GND	75		

(1). PCIe 控制 IO 电平为 3.3V。

### 3.8. Wi-Fi

RUBIK Pi 3 板载无线通讯模块，支持 IEEE 802.11 a/b/g/n/ac Wi-Fi。板载 PCB 天线，无需外接天线。

### 3.9. 蓝牙

RUBIK Pi 3 板载无线通讯模块，支持 BT5.2，与 Wi-Fi 共用 PCB 天线，无需外接天线。支持蓝牙数据传输，蓝牙音频等应用。

### 3.10. 风扇接口



图3-7. 风扇接口

风扇接口使用 1mm 间距 4-pin 连接器，Pin 定义和主板安装孔兼容 Raspberry Pi 5 官方风扇。接口支持 PWM 调速，支持 5V 供电风扇，使用风扇的最大额定电流不超过 200mA。

表 3-5. 风扇接口引脚定义

引脚编号	引脚名称
1	NC
2	GND
3	PWM_OUT <sup>(1)</sup>
4	VCC5V_OUT

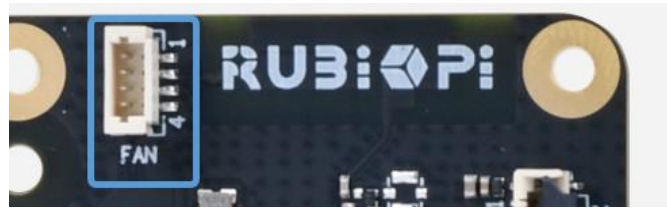
(1). PWM IO 为 5V 电平。

### 3.11. RTC 电池接口



图3-8. RTC 电池接口

RTC 电池接口使用 1.25mm 间距 2-pin 连接器。仅限 3V 纽扣电池接入，正常工作时支持的电压范围为 2 – 3.25V。

表 3-6. RTC 电池接口引脚定义

引脚编号	引脚名称
1	VCC3V_IN
2	GND

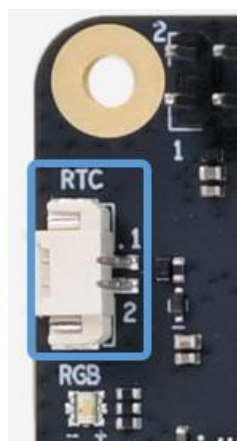
## 3.12. Micro USB 转 UART 调试接口



图 3-9. Micro USB

RUBIK Pi 3 板上集成了 WCH CH343, USB 转串口 TTL IC, 可使用 Micro USB 线通过上位机直接访问主控的串口 log。串口波特率默认为 115200, 8 个数据位, 1 停止位, 无校验位。

CH343 驱动官方下载链接: [驱动](#)。

## 3.13. 按键

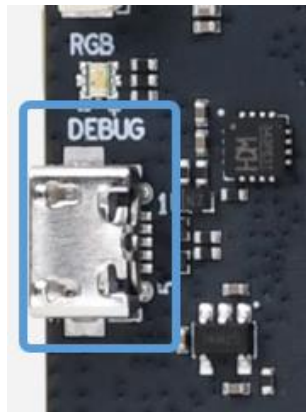
### 3.13.1. PWR 键

插入电源线后, 短按开机键, 指示灯闪烁一次, 表明开机成功, 设备开始正常工作。

### 3.13.2. EDL 键

强制下载按键。插入电源后, 与 PWR 按键同时按住 3s 以上, 设备进入强制下载模式 (9008)。

## 3.14. LED

### 3.14.1. 电源指示 LED

当插入符合要求（支持 12V 3A PD 协议）电源时，黄绿色指示灯常亮，表示设备可以正常工作。



图3-10. 电源指示 LED

### 3.14.2. RGB LED

RUBIK Pi 3 板载一颗 RGB 3 合 1 LED，支持 PWM 调光。



图3-11. RGB LED



## 4. 注意事项

### 4.1. 工作环境

RUBIK Pi 3 可在  $-20^{\circ}\text{C}$  –  $70^{\circ}\text{C}$  的环境温度下工作，使用过程中请密切关注 CPU 的温度并进行相应的散热处理，确保 CPU 的工作温度不超过  $85^{\circ}\text{C}$ ，避免出现性能下降或降频等现象影响使用体验。

### 4.2. 静电防护

请注意静电防护，任何情况下，不要用手直接接触板上元器件！

### 4.3. 警告

RUBIK Pi 3 使用的任何外置电源应符合所在国家的相关法规和标准。电源应提供 12V DC 和 3A 最小额定电流。

### 4.4. 安全使用说明

- 此产品不可超频。
- 请勿将本产品暴露在水或潮湿环境中进行操作。
- 请勿将其置于导电表面上。
- 请勿将此产品靠近任何热源；此产品仅适合在正常室温中使用，以确保可靠运行。
- 请勿将电路板暴露于高强度光源下使用（例如氙气闪光灯或激光）。
- 在通风良好的环境中运行此产品，在使用过程中请勿将其覆盖。
- 使用时，请将本产品放在稳定、平坦、绝缘的表面上，请勿让它接触导电物品。
- 拿放本产品时请小心，以免对印刷电路板和连接器造成机械或电气损坏。
- 本产品通电时避免接触、拿放。拿放时应只接触产品边缘，以最大限度降低静电放电损坏的风险。
- RUBIK Pi 3 使用的任何外设或设备应符合使用国家的相关标准，并进行相应标记，以确保满足安全和性能要求。



## 附录 1. Compliance and Certificate Information

### FCC statements:

Caution!

Any changes or modifications not expressly approved by the party responsible for compliance could void the user's authority to operate the equipment.

This device complies with FCC radiation exposure limits set forth for an uncontrolled environment and it also complies with Part 15 of the FCC RF Rules. This equipment must be installed and operated in accordance with provided instructions and the antenna(s) used for this transmitter must be installed to provide a separation distance of at least 20 cm from all persons and must not be co-located or operating in conjunction with any other antenna or transmitter. End-users and installers must be provided with antenna installation instructions and consider removing the no-collocation statement.

This device complies with Part 15 of the FCC Rules. Operation is subject to the following two conditions:

- (1) This device may not cause harmful interference.
- (2) This device must accept any interference received, including interference that may cause undesired operation.

NOTE: This equipment has been tested and found to comply with the limits for a Class B digital device, pursuant to Part 15 of the FCC Rules. These limits are designed to provide reasonable protection against harmful interference in a residential installation. This equipment generates and can radiate radio frequency energy and, if not installed and used in accordance with the instructions, may cause harmful interference to radio communications. However, there is no guarantee that interference will not occur in a particular installation. If this equipment does cause harmful interference to radio or television reception, which can be determined by turning the equipment off and on, the user is encouraged to try to correct the interference by one or more of the following measures:

- Reorient or relocate the receiving antenna.
- Increase the separation between the equipment and receiver.
- Connect the equipment to an outlet on a circuit different from that to which the receiver is connected.
- Consult the dealer or an experienced radio/TV technician for help.

### OEM INTEGRATION INSTRUCTIONS:

This device is intended only for OEM integrators under the following conditions:

The module must be installed in the host equipment such that 20 cm is maintained between the



antenna and users, and the transmitter module may not be co-located with any other transmitter or antenna. The module shall be only used with the internal on-board antenna that has been originally tested and certified with this module. External antennas are not supported. As long as these 3 conditions above are met, further transmitter tests will not be required.

However, the OEM integrator is still responsible for testing their end product for any additional compliance requirements required with this module installed (for example, digital device emissions, PC peripheral requirements, etc.). The end product may need Verification testing, Declaration of Conformity testing, a Permissive Class II Change, or new Certification. Please involve an FCC certification specialist in order to determine what will be exactly applicable to the end product.

Validity of using the module certification:

In the event that these conditions cannot be met (for example certain laptop configurations or co-location with another transmitter), then the FCC authorization for this module in combination with the host equipment is no longer considered valid and the FCC ID of the module cannot be used on the final product. In these circumstances, the OEM integrator will be responsible for re-evaluating the end product (including the transmitter) and obtaining a separate FCC authorization. In such cases, please involve an FCC certification specialist in order to determine if a Permissive Class II Change or new Certification is required.

Upgrade Firmware:

The software provided for firmware upgrade will not be capable of affecting any RF parameters as certified for the FCC for this module, in order to prevent compliance issues.

End product labeling:

This transmitter module is authorized only for use in devices where the antenna may be installed such that 20 cm may be maintained between the antenna and users. The final end product must be labeled in a visible area with the following: "Contains FCC ID: 2AOHHRUBIKPI3".

The OEM integrator has to be aware not to provide information to the end user regarding how to install or remove this RF module in the user's manual of the end product that integrates this module. The end user manual shall include all required regulatory information/warning as shown in this manual.

**CAUTION:** Exposure to Radio Frequency Radiation.

The antenna shall be mounted in such a manner to minimize the potential for human contact during normal operation. The antenna should not be contacted during operation to avoid the possibility of exceeding the FCC radio frequency exposure limit.



Requirement per KDB996369 D03

## 2.2 List of applicable FCC rules

List the FCC rules that are applicable to the modular transmitter. These are the rules that specifically establish the bands of operation, the power, spurious emissions, and operating fundamental frequencies. DO NOT list compliance to unintentional-radiator rules (Part 15 Subpart B) since that is not a condition of a module grant that is extended to a host manufacturer. See also Section 2.10 below concerning the need to notify host manufacturers that further testing is required.<sup>3</sup>

Explanation: This module meets the requirements of FCC part 15C(15.247). part 15E(15.407)

## 2.3 Summarize the specific operational use conditions

Describe use conditions that are applicable to the modular transmitter, including for example any limits on antennas, etc. For example, if point-to-point antennas are used that require reduction in power or compensation for cable loss, then this information must be in the instructions. If the use condition limitations extend to professional users, then instructions must state that this information also extends to the host manufacturer's instruction manual. In addition, certain information may also be needed, such as peak gain per frequency band and minimum gain, specifically for master devices in 5 GHz DFS bands.

Explanation: The EUT has a PCBA antenna, and the antenna uses a permanently attached antenna which is not replaceable.

## 2.4 Limited module procedures

If a modular transmitter is approved as a "limited module", then the module manufacturer is responsible for approving the host environment that the limited module is used with. The manufacturer of a limited module must describe, both in the filing and in the installation instructions, the alternative means that the limited module manufacturer uses to verify that the host meets the necessary requirements to satisfy the module limiting conditions.

A limited module manufacturer has the flexibility to define its alternative method to address the conditions that limit the initial approval, such as shielding, minimum signaling amplitude, buffered modulation/data inputs, or power supply regulation. The alternative method could include that the limited module manufacturer reviews detailed test data or host designs prior to giving the host manufacturer approval.

This limited module procedure is also applicable for RF exposure evaluation when it is necessary to demonstrate compliance in a specific host. The module manufacturer must state how control of the product into which the modular transmitter will be installed will be maintained such that full compliance of the product is always ensured. For additional hosts other than the specific host originally granted with a limited module, a Class II permissive change is required on the module grant to register the additional host as a specific host also approved with the module.

Explanation: The module is not a limited module.





## 2.5 Trace antenna designs

For a modular transmitter with trace antenna designs, see the guidance in Question 11 of KDB Publication 996369 D02 FAQ – Modules for Micro-Strip Antennas and traces. The integration information shall include for the TCB review the integration instructions for the following aspects:

Layout of trace design, parts list (BOM), antenna, connectors, and isolation requirements.

- a) Information that includes permitted variances (e.g., trace boundary limits, thickness, length, width, shape(s), dielectric constant, and impedance as applicable for each type of antenna);
- b) Each design shall be considered a different type (e.g., antenna length in multiple(s) of frequency, the wavelength, and antenna shape (traces in phase) can affect antenna gain and must be considered);
- c) The parameters shall be provided in a manner permitting host manufacturers to design the printed circuit (PC) board layout;
- d) Appropriate parts by manufacturer and specifications;
- e) Test procedures for design verification; and
- f) Production test procedures for ensuring compliance.

The module grantee shall provide a notice that any deviation(s) from the defined parameters of the antenna trace, as described by the instructions, require that the host product manufacturer must notify the module grantee that they wish to change the antenna trace design. In this case, a Class II permissive change application is required to be filed by the grantee, or the host manufacturer can take responsibility through the change in FCC ID (new application) procedure followed by a Class II permissive change application.

Explanation: Yes, the module has trace antenna designs, and this manual has shown the layout of trace design, antenna, connectors, and isolation requirements.

## 2.6 RF exposure considerations

It is essential for module grantees to clearly and explicitly state the RF exposure conditions that permit a host product manufacturer to use the module. Two types of instructions are required for RF exposure information: (1) to the host product manufacturer, to define the application conditions (mobile, portable – xx cm from a person's body); and (2) additional text needed for the host product manufacturer to provide to end users in their end-product manuals. If RF exposure statements and use conditions are not provided, then the host product manufacturer is required to take responsibility for the module through a change in FCC ID (new application).

Explanation: This module complies with FCC RF radiation exposure limits set forth for an uncontrolled environment. This equipment should be installed and operated with a minimum distance of 20 centimeters between the radiator and your body. This module is designed to comply with the FCC statement, FCC ID is: 2AOHHRUBIKPI3.



## 2.7 Antennas

A list of antennas included in the application for certification must be provided in the instructions. For modular transmitters approved as limited modules, all applicable professional installer instructions must be included as part of the information to the host product manufacturer. The antenna list shall also identify the antenna types (monopole, PIFA, dipole, etc. (note that for example an "omni-directional antenna" is not considered to be a specific "antenna type")).

For situations where the host product manufacturer is responsible for an external connector, for example with an RF pin and antenna trace design, the integration instructions shall inform the installer that a unique antenna connector must be used on the Part 15 authorized transmitters used in the host product. The module manufacturers shall provide a list of acceptable unique connectors.

Explanation: The EUT has a Chip Antenna, and the antenna uses a permanently attached antenna which is unique.

## 2.8 Label and compliance information

Grantees are responsible for the continued compliance of their modules to the FCC rules. This includes advising host product manufacturers that they need to provide a physical or e-label stating "Contains FCC ID" with their finished product. See Guidelines for Labeling and User Information for RF Devices – KDB Publication 784748.

Explanation: The host system using this module, should have a label in a visible area indicating the following text: "Contains FCC ID: 2AOHHRUBIKPI3"

## 2.9 Information on test modes and additional testing requirements

Additional guidance for testing host products is given in KDB Publication 996369 D04 Module Integration Guide. Test modes should take into consideration different operational conditions for a stand-alone modular transmitter in a host, as well as for multiple simultaneously transmitting modules or other transmitters in a host product.

The grantee should provide information on how to configure test modes for host product evaluation for different operational conditions for a stand-alone modular transmitter in a host, versus with multiple, simultaneously transmitting modules or other transmitters in a host.

Grantees can increase the utility of their modular transmitters by providing special means, modes, or instructions that simulate or characterize a connection by enabling a transmitter. This can greatly simplify a host manufacturer's determination that a module as installed in a host complies with FCC requirements.

Explanation: The top band can increase the utility of our modular transmitters by providing instructions that simulate or characterize a connection by enabling a transmitter.

## 2.10 Additional testing, Part 15 Subpart B disclaimer

The grantee should include a statement that the modular transmitter is only FCC-authorized for the



specific rule parts (i.e., FCC transmitter rules) listed on the grant, and that the host product manufacturer is responsible for compliance with any other FCC rules that apply to the host not covered by the modular transmitter grant of certification. If the grantee markets their product as being Part 15 Subpart B compliant (when it also contains unintentional-radiator digital circuitry), then the grantee shall provide a notice stating that the final host product still requires Part 15 Subpart B compliance testing with the modular transmitter installed.

Explanation: The module does not include unintentional-radiator digital circuitry, so the module does not require an evaluation by FCC Part 15 Subpart B. The host should be evaluated by the FCC Subpart B.

### IC statements:

This device contains licence-exempt transmitter(s)/receiver(s) that comply with Innovation, Science and Economic Development Canada's licence-exempt RSS(s). Operation is subject to the following two conditions:

- (1) This device may not cause interference.
- (2) This device must accept any interference, including interference that may cause undesired operation of the device.

L'émetteur/récepteur exempt de licence contenu dans le présent appareil est conforme aux CNR d'Innovation, Sciences et Développement économique Canada applicables aux appareils radio exempts de licence. L'exploitation est autorisée aux deux conditions suivantes:

- (1) L'appareil ne doit pas produire de brouillage;
- (2) L'appareil doit accepter tout brouillage radioélectrique subi, même si le brouillage est susceptible d'en compromettre le fonctionnement.

The device meets the exemption from the routine evaluation limits in section 2.5 of RSS 102 and compliance with RSS-102 RF exposure, users can obtain Canadian information on RF exposure and compliance.

Le dispositif rencontre l'exemption des limites courantes d'évaluation dans la section 2.5 de RSS 102 et la conformité à l'exposition de RSS-102 rf, utilisateurs peut obtenir l'information canadienne sur l'exposition et la conformité de rf.

the device for operation in the band 5150-5250 MHz is only for indoor use to reduce the potential for harmful interference to co-channel mobile satellite systems

les dispositifs fonctionnant dans la bande 5150-5250 MHz sont réservés uniquement pour une utilisation à l'intérieur afin de réduire les risques de brouillage préjudiciable aux systèmes de satellites mobiles utilisant les mêmes canaux;

1. the device for operation in the band 5150–5250 MHz is only for indoor use to reduce the potential for harmful interference to co-channel mobile satellite systems;
2. for devices with detachable antenna(s), the maximum antenna gain permitted for devices in the bands 5250-5350 MHz and 5470-5725 MHz shall be such that the equipment still complies with the e.i.r.p. limit;



3. for devices with detachable antenna(s), the maximum antenna gain permitted for devices in the band 5725-5850 MHz shall be such that the equipment still complies with the e.i.r.p. limits specified for point-to-point and non-point-to-point operation as appropriate.
1. les dispositifs fonctionnant dans la bande 5150-5250 MHz sont réservés uniquement pour une utilisation à l'intérieur afin de réduire les risques de brouillage préjudiciable aux systèmes de satellites mobiles utilisant les mêmes canaux;
2. le gain maximal d'antenne permis pour les dispositifs utilisant les bandes 5250-5350 MHz et 5470-5725 MHz doit se conformer à la limite de p.i.r.e.;
3. le gain maximal d'antenne permis (pour les dispositifs utilisant la bande 5725-5850 MHz) doit se conformer à la limite de p.i.r.e. spécifiée pour l'exploitation point à point et non point à point, selon le cas.

Caution!

Any changes or modifications not expressly approved by the party responsible for compliance could void the user's authority to operate the equipment.

#### **CE statements:**

Do not use the module in the environment at too high or too low temperature, never expose the module under strong sunshine or too wet environment.

RF exposure information: The Maximum Permissible Exposure (MPE) level has been calculated based on a distance of  $d=20$  cm between the device and the human body. To maintain compliance with RF exposure requirement, use product that maintain a 20cm distance between the device and human body.

#### **EU Regulatory Conformance**

**Hereby we,**

Name of manufacturer: Thundercomm Technology Co., Ltd

Address: No. 107, Middle Datagu Road, Xiantao Street, Yubei District, Chongqing, China, 401122

**declare that this DoC is issued under our sole responsibility and that this product:**

Product description: Rubik Pi

Type designation(s): RUBIK Pi 3, RUBIK Pi 3 Lite

Trademark: Rubik Pi

**Object of the declaration: [ Model: RUBIK Pi 3, RUBIK Pi 3 Lite, The device is Rubik Pi, it supports 2.4G WiFi, 5G WiFi, BT functions. For more details, please refer to the user manual. ]**

**is in conformity with the relevant Union harmonization legislation:**

**Radio Equipment Directive 2014/53/EU:**

with reference to the following standards applied:

<b>Safety</b>	IEC 62368-1: 2018 EN IEC 62368-1: 2020+A11: 2020
<b>Electromagnetic compatibility</b>	ETSI EN 301 489-1 V2.2.3(2019-11) Draft ETSI EN 301 489-17 V3.2.6 (2023-06) EN 55032: 2015+A1:2020 EN 55035: 2017+A11:2020 EN IEC 61000-3-2: 2019+A2:2024 EN 61000-3-3: 2013+A2:2021
<b>Radio frequency spectrum usage</b>	ETSI EN 300 328 V2.2.2(2019-07); ETSI EN 300 328 V2.2.2(2019-07); ETSI EN 301 893 V2.2.1(2017-05); ETSI EN 300 440 V2.2.1(2018-07)
<b>Health</b>	EN IEC 62311: 2020; EN 50665:2017
<b>Article 3.3.g emergency services access</b>	N/A

**The Notified Body Kiwa Nederland B.V. , with Notified Body number 0063 performed:****Applicable Modules: B+C****Where applicable:**The issued EU-type examination certificate: NA**Accessories:**

**Software version:** LE 1.0 *(Note: Some software updates will be released by the manufacturer to fix some bug or enhance some function after placing on the market. All versions released by the manufacturer have been verified and still compliance with the related rules. All RF parameters (e.g.: frequency range, output power) are not accessible to the user, and can't be changed by the user.)*

**Signed for and on behalf of:**

March 26, 2025 China

shaolei.ke Project Manager

Place and date of issue

Name, Function, signature

The device for operation in the band 5150–5350 MHz is only for indoor use to reduce the potential for harmful interference to co-channel mobile satellite systems.



	AT	BE	BG	CH	CY	CY	DE	DK
	EE	EL	ES	FI	FR	HR	HU	IE
	IS	IT	LI	LT	LU	LV	MT	NL
	PL	PT	RO	SE	SI	SK	TR	UK(NI)

**Frequency bands and power**

Radio	Operation Frequency	Max. Output Power
Bluetooth	2402-2480 MHz	5.74 dBm
2.4G Wi-Fi	2412-2472 MHz	17.37 dBm
5G Wi-Fi	5.150-5.250 GHz	17.22 dBm
	5.250-5.350 GHz	17.01 dBm
	5.470-5.725 GHz	17.27 dBm
	5.725-5.825 GHz	13.02 dBm

Manufacturer: Thundercomm Technology Co., Ltd

Manufacturer Address: No. 107, Middle Datagu Road, Xiantao Street, Yubei District, Chongqing, China, 401122.